

MODEL

REC199i
(REU-VE2737FFC-US)

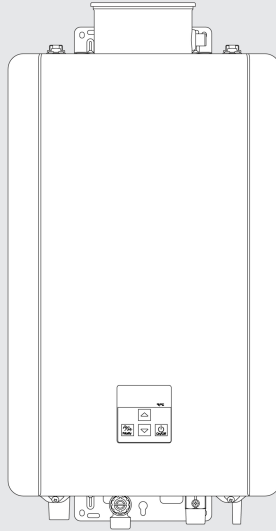

CSA/ANSI Z21.10.3
CSA 4.3



For the Conversion from Natural Gas (NG) to Liquid Propane Gas (LPG)
For the Conversion from Liquid Propane Gas (LPG) to Natural Gas (NG)
For Adjustment at High Altitude (Greater than 2,000 ft / 610 m)

Demand Duo™ R-Series (REC)

Gas Conversion Manual

Rinnai



WARNING

This conversion kit shall be installed by a qualified service agency in accordance with the manufacturer's instructions and all applicable codes and requirements of the authority having jurisdiction. The information in these instructions must be followed to minimize the risk of fire or explosion or to prevent property damage, personal injury or death. The qualified service agency is responsible for the proper installation of this kit. The installation is not proper and complete until the operation of the converted appliance is checked as specified in the manufacturer's instructions supplied with the kit.

Model

Model: REC199i (REU-VE2737FFC-US)

For use with Demand Duo R-Series Commercial Systems Only.

Contents

| | |
|--------------------------------------|----------|
| 1. Safety | 3 |
| 1.1 Safety Symbols | 3 |
| 2. Technical Data..... | 4 |
| 3. Parts List..... | 4 |
| 3.1 Parts List | 4 |
| 3.2 Tools Needed..... | 4 |
| 4. Gas Conversion Steps | 5 |
| 4.1 Gas Manifold Procedure..... | 5 |
| 4.2 Adjust Parameter Settings..... | 7 |
| 4.3 Adjust Gas Pressure Settings ... | 8 |
| 4.4 Check Operation..... | 9 |
| 4.5 Operating Instructions | 10 |

1. Safety

The appliance must be installed in accordance with:

- Local codes or, in the absence of local codes, the National Fuel Gas Code, ANSI Z223.1/NFPA 54 and/or CSA B149.1, Natural Gas and Propane Installation Code.
- The Manufactured Home Construction and Safety Standard, Title 24 CFR, Part 3280 and/or CAN/CSA Z240 MH Series, Mobile Homes, Series M86.

For installations in Canada, the conversion shall be carried out in accordance with the requirements of the provincial authorities having jurisdiction and in accordance with the requirements of the CGA-B149.1, Natural Gas and Propane Installation Code.

WARNING

- If subsequent conversions are made, then a new conversion label must be placed on the water heater to accurately reflect the gas type.
- Failure to correctly assemble the components according to these instructions may result in a gas leak or explosion.

WARNING

Read the section “For Your Safety Read Before Operating” in section “4.5 Operating Instructions” before starting the steps below.

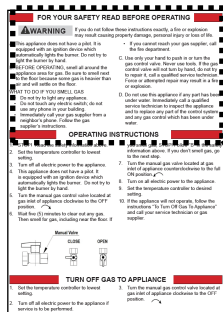

FOR YOUR SAFETY READ BEFORE OPERATING

WARNING

If you do not follow these instructions exactly, a fire or explosion may result causing property damage, personal injury or loss of life.

- This appliance does not have a pilot. It is equipped with an ignition device which automatically lights the burner. Do not try to light the burner by hand.
 - If you cannot reach your gas supplier, call the fire department.
 - BEFORE OPERATING, smell all around the appliance area for gas. Be sure to smell next to the floor because some gas is heavier than air and will settle on the floor.
 - Use only your hand to push in or turn the gas control valve. Never use tools. If the gas control valve will not turn by hand, do not try to repair it, call a qualified service technician. Force or attempted repair may result in a fire or explosion.
- WHAT TO DO IF YOU SMELL GAS
- Do not try to light any appliance.
 - Do not touch any electric switch; do not use any phone in your building.
 - Immediately call your gas supplier from a neighbor's phone. Follow the gas supplier's instructions.
 - Do not use this appliance if any part has been under water. Immediately call a qualified service technician to inspect the appliance and to replace any part of the control system and any gas control which has been under water.

Confirm that the inlet gas pressure is between the minimum and maximum pressures allowed for the gas type of this appliance.

1.1 Safety Symbols



Safety alert symbol. Alerts you to potential hazards that can kill or hurt you and others.



DANGER

Indicates an imminently hazardous situation which, if not avoided, will result in personal injury or death.



WARNING

Indicates a potentially hazardous situation which, if not avoided, could result in personal injury or death.



CAUTION

Indicates a potentially hazardous situation which, if not avoided, could result in minor or moderate injury. It may also be used to alert against unsafe practices.

2. Technical Data

Table 1. Technical Data

| Model | | REC199i (REU-VE2737FFC-US) | Forced Low (W.C.) | Forced High (W.C.) |
|-------------------------|-------------|---|-------------------------|--------------------------|
| Gas Consumption (Btu/h) | Minimum | 11,900 | | |
| | Maximum | 199,000 | | |
| Gas Supply Pressure | Natural Gas | Minimum: 4.0 in. (1.00 kPa) W.C. Maximum: 10.5 in. (2.61 kPa) W.C. | 0.7 | 2.8 |
| | Propane | Minimum: 8.0 in. (1.99 kPa) W.C. Maximum: 13.0 in. (3.24 kPa) W.C. | 1.1 | 4.4 |

The input rate can be verified by following the procedure in the National Fuel Gas Code (NFPA54 / ANSI Z223.1, 2006 or latest edition).

3. Parts List

3.1 Parts List

The gas manifold is stamped either “LP” for Liquid Propane Gas or “NG” for Natural Gas.

Table 2. Parts List

| Model | To Gas Type | Kit Number ¹ | Gas Manifold | Conversion Rating Plate | Conversion Manual |
|---------|-------------|-------------------------|--------------|-------------------------|-------------------|
| REC199i | LP | 103000112 | 106000252 | 100000816 | 100000815 |
| | NG | 103000113 | 106000253 | 100000817 | |

¹ Kit includes gas manifold (gas-specific), manifold gaskets (upper and lower), conversion rating plate and conversion manual.

3.2 Tools Needed

- Philips Head Screwdriver
- Manometer

4. Gas Conversion Steps

4.1 Gas Manifold Procedure

1. Remove front panel from water heater.
2. Turn off gas.
3. Disconnect electrical power.
4. Using a Phillips head screwdriver, remove screw securing controller and controller mounting plate to water heater (A in Figure 1).
5. Remove controller and controller mounting plate (B in Figure 1).

Figure 1

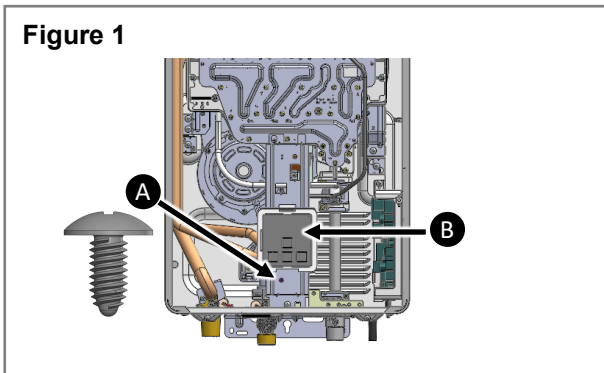

6. Remove ignitor wire (Figure 2).

Figure 2

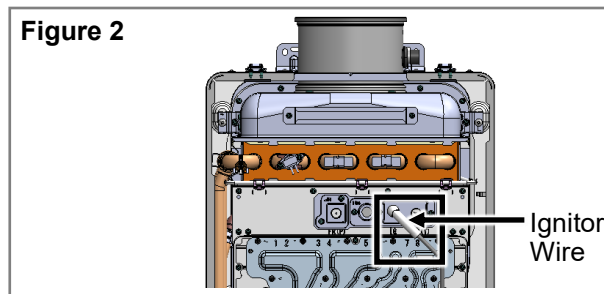

7. Remove screw securing ignitor and place ignitor aside (Figure 3).

Figure 3

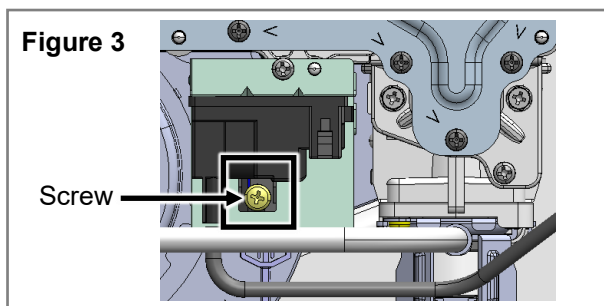

8. Using a Phillips head screwdriver, remove the 5 screws around perimeter of existing gas manifold (Figure 4).

Figure 4

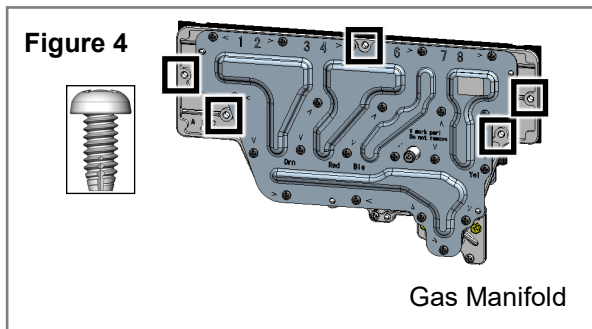

9. Using a Phillips head screwdriver, remove the 2 hex head screws securing existing gas manifold to gas valve (Figure 5).

Figure 5

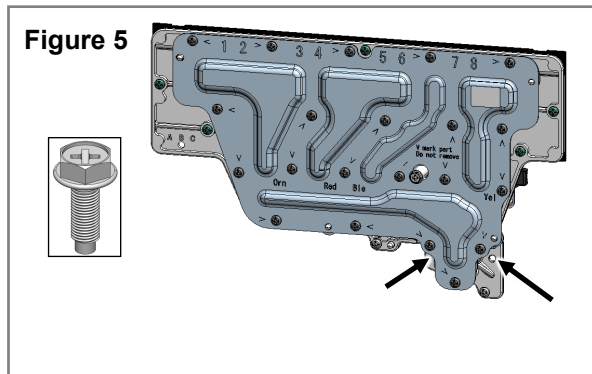

10. Rotate existing gas manifold assembly to access solenoid wire connections (Figure 6).

Figure 6

Solenoid Wire Connections

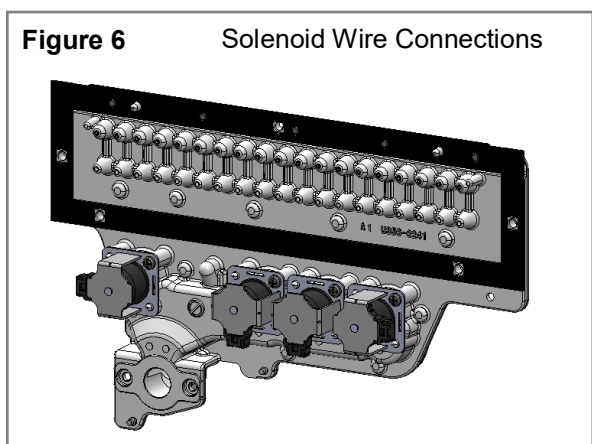

11. Disconnect solenoid wires from all four gas solenoids (Figure 7).

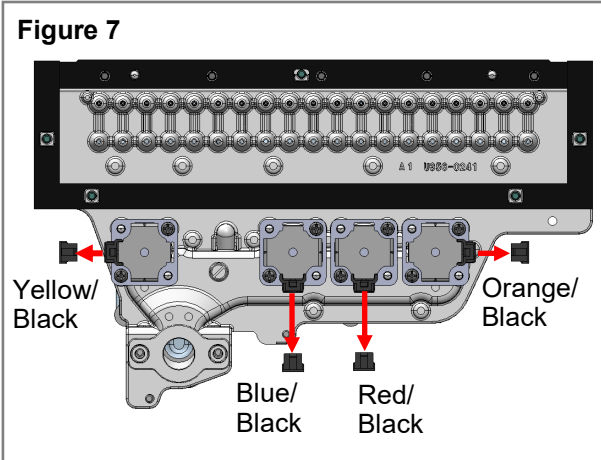

12. Connect wires to new gas manifold.
13. Inspect new gas manifold gaskets for damage and confirm gasket is installed at gas control valve (Figure 8). Ensure the ribbed side of the gasket is facing outward.

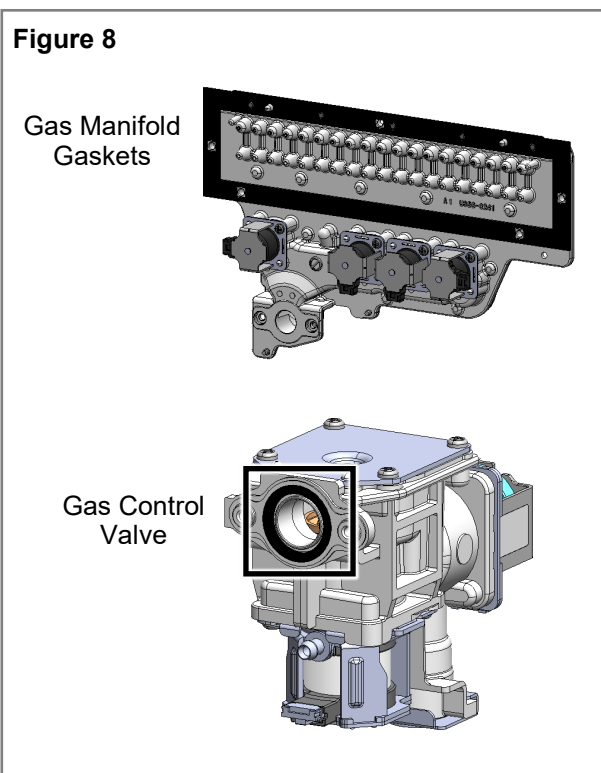

14. Position new gas manifold to burner case on heat exchanger assembly (Figure 9).

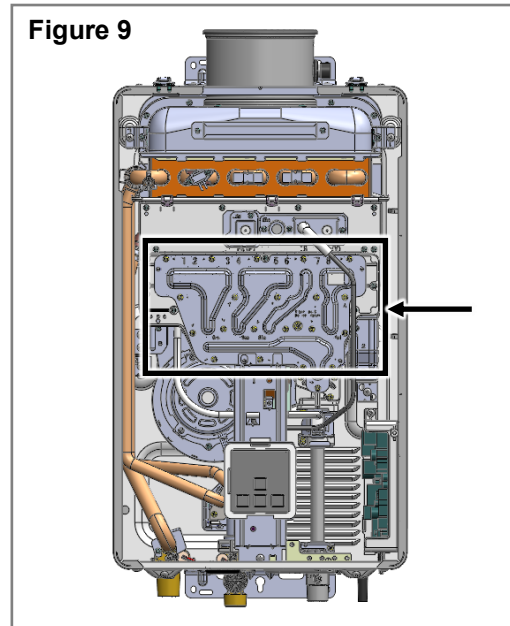

15. Start to reinstall the 2 hex head screws (do not completely tighten), and then start to reinstall the 5 screws to line up the burner (Figures 4 and 5).

After all screws have been started and are properly aligned, tighten all 7 screws.

NOTICE Be careful not to tear or pinch wires between manifold and valve.

16. Reinstall one screw securing ignitor to gas manifold (Figure 3).
17. Reconnect ignitor wire (Figure 2).
18. Reinstall one screw securing controller and controller mounting plate to water heater (A in Figure 1).
19. Proceed to the next section to continue the conversion steps.

4.2 Adjust Parameter Settings

▶ IMPORTANT

Confirm that the inlet gas pressure is between the minimum and maximum pressures allowed for this appliance.

⚠ CAUTION ⚡

- Do not touch any other areas on the PC board other than the described buttons while power is supplied to the appliance. Parts of the PC board are supplied with 120 VAC.
- Do not touch the areas at or near the heat exchanger or hot water lines; these areas become hot and could cause burns.

1. Locate the PC board (lower right side of unit) (Figure 10).
2. Locate the two push buttons (“A” and “B”) on the PC board (Figure 10). Apply power.

Figure 10

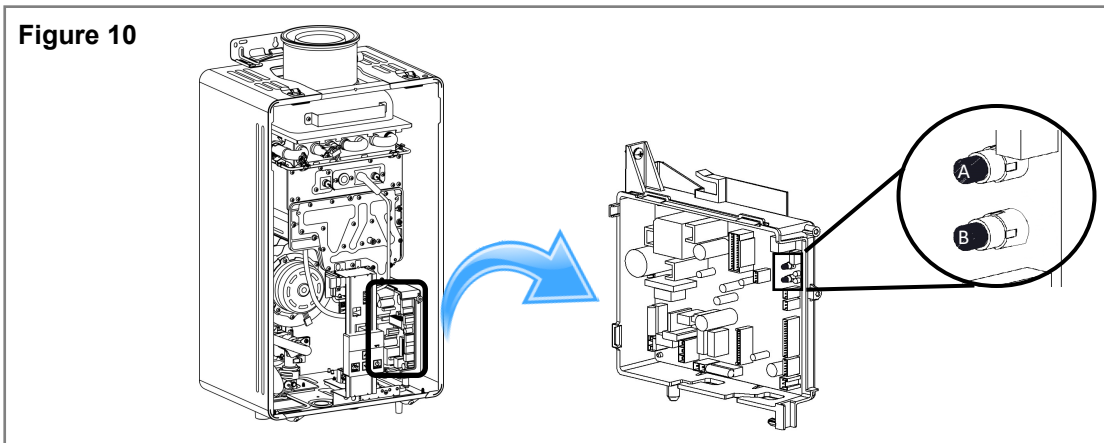

3. Press button “A” for one second to enter parameter settings mode.
4. Press the ▲ (Up) and ▼ (Down) arrows on the controller to select setting “10” (Figure 11A).
5. After setting “10” is selected, press the “On/Off” button to change the selection. Select “10R” for Propane (LP) or “10b” for Natural Gas (NG) (Figures 11B and 11C).

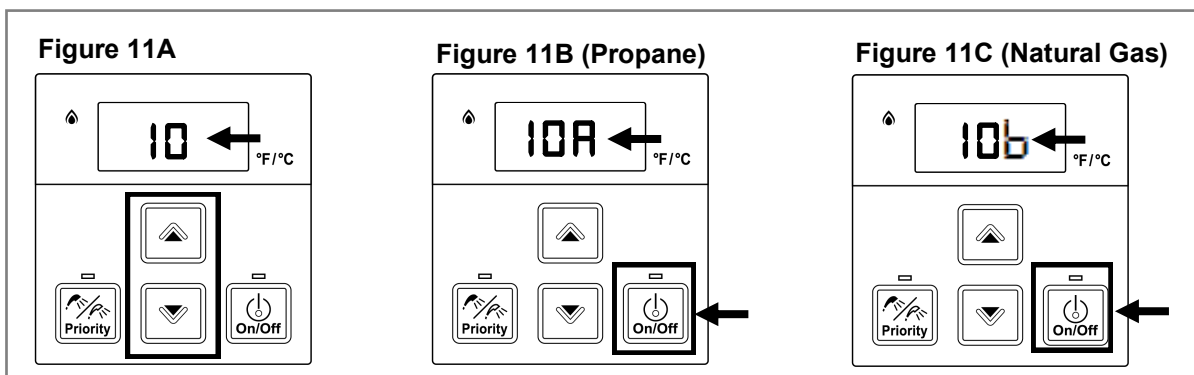

6. To exit and save the parameter settings, press the “A” button on the PC board for one second.
7. Proceed to the next section to continue the conversion steps.

4.3 Adjust Gas Pressure Settings

Confirm that the inlet gas pressure is between the minimum and maximum pressures allowed for this appliance (see Table 1 in section “2. Technical Data.”)

CAUTION ⚡

Do not touch any other areas on the PC board besides the “SW” switches while power is supplied to the appliance. Parts of the PC board are supplied with 120 volts AC.

CAUTION 🔥

Do not touch the areas at or near the heat exchanger or hot water lines. These areas become very hot and could cause burns.

1. Turn off the gas supply.
2. Turn off the 120 V power supply.
3. Remove the front panel from the appliance.
4. Turn on the 120 V power supply.
5. Check the gas type using the data plate on the side of the unit and parameter setting 10 (refer to section “4.2 Adjust Parameter Settings”) (A=LPG, b=NG).
6. Remove test port screw and attach the manometer to the burner test point located on the manifold (Figure 12).

Figure 12

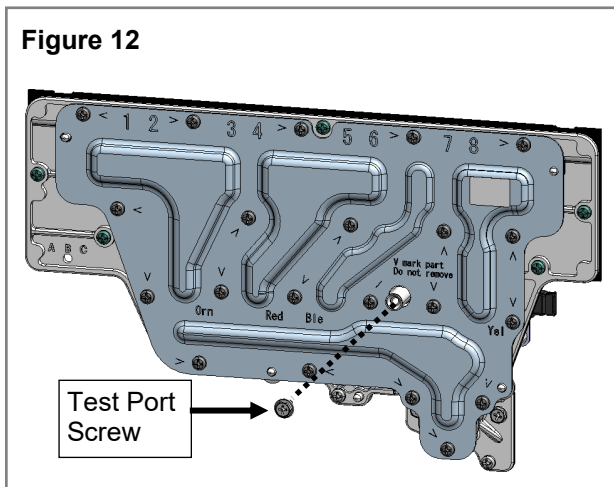

7. Turn on the gas supply.
8. Flow water through the water heater at the maximum flow rate obtainable. (At least 3 gallons per minute is recommended. If there is not enough water flowing, the water heater could shut off or sustain damage due to overheating.)
9. Push and hold “B” button (Figure 10). “IF” will appear on the display.
10. Push and hold “A” button (Figure 10). “FL” (Forced Low) will appear on the display.
11. Push and hold “A” button again. “FH” (Forced High) will appear on the display.
12. While in “Forced Low” or “Forced High”, use the Up button on the controller to increase the pressure. Use the Down button to decrease the pressure. Refer to Table 1 in section “2. Technical Data” for values.
13. To exit “Forced Low” or “Forced High”, push and hold “B” button. “2L” will appear on the display.
14. Push and hold “B” button again. “3C” will appear on the display (indoor models only).
15. Push and hold “B” button again. “4t” will appear on the display.
16. Push and hold “B” button again. The set temperature will appear on the display (indoor models only).
17. Close hot water taps.
18. Turn off the gas supply and 120 V power supply.
19. Remove the manometer and re-install the test port screw (Figure 12).
20. Turn on the gas supply and 120 V power supply.
21. Operate the unit and check for gas leaks.
22. Install the front panel.

4.4 Check Operation

WARNING

Read the section "For Your Safety Read Before Operating" in section "4.5 Operating Instructions" before starting the steps below.

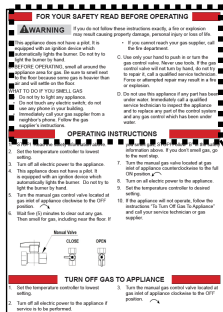

FOR YOUR SAFETY READ BEFORE OPERATING

WARNING If you do not follow these instructions exactly, a fire or explosion may result causing property damage, personal injury or loss of life.

- A. This appliance does not have a pilot. It is equipped with an ignition device which automatically lights the burner. Do not try to light the burner by hand.
 - If you cannot reach your gas supplier, call the fire department.
- B. BEFORE OPERATING, smell all around the appliance area for gas. Be sure to smell next to the floor because some gas is heavier than air and will settle on the floor.
 - Use only your hand to push in or turn the gas control valve. Never use tools. If the gas control valve will not turn by hand, do not try to repair it, call a qualified service technician. Force or attempted repair may result in a fire or explosion.
- C. Do not use this appliance if any part has been under water. Immediately call a qualified service technician to inspect the appliance and to replace any part of the control system and any gas control which has been under water.

WHAT TO DO IF YOU SMELL GAS

- Do not try to light any appliance.
- Do not touch any electric switch; do not use any phone in your building.
- Immediately call your gas supplier from a neighbor's phone. Follow the gas supplier's instructions.

1. Press the "On/Off" button on the controller to start the unit. The LED display will illuminate, the combustion fan will begin to run if water is flowing, and the spark will ignite the main burner.
2. This water heater has an automatic ignition system. When the main burner has lit, the "In Use" lamp will glow red and the spark will stop.
3. Check that the burner flames are operating normally. The flame can be seen through the circular window above the burner. When operating normally, the burner flame should burn evenly over the entire surface. The flame should be clear, blue and stable. A yellow flame is abnormal and maintenance is required (Figure 13).

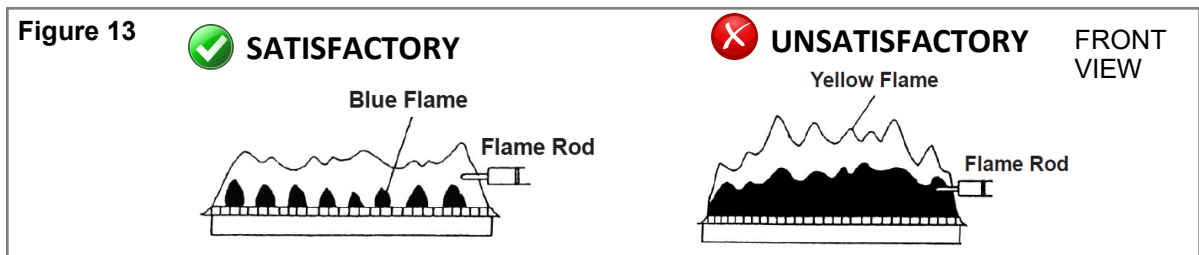

4. If the unit operation is normal, turn off the unit by pressing the "On/Off" button and reinstall the front panel.

CAUTION



Do not touch the areas at or near the heat exchanger or hot water lines; these areas become hot and could cause burns.

5. Enter the required information on the conversion rating plate label (Figure 14).
6. Affix the conversion rating plate label as close as possible to the existing rating plate on the appliance.

Figure 14. Required fields on the conversion rating plate label

Water Heater Certified for use in the United States

Model :

Conversion Kit # : for Gas

Gas Supply Pressure : Min. W.C. (1.99 kPa) - Max. W.C. (3.36 kPa)

Manifold Pressure : Low W.C. (0.27 kPa) - High W.C. (1.09 kPa)

Input Rating : Maximum BTU/H Minimum BTU/H

This water heater was converted on _____ to _____ gas with kit No. _____ by _____ (Name and address of organization making this conversion, who accepts the responsibility for the correctness of this conversion)

This appliance has been converted for use with gas.

4.5 Operating Instructions

The following operating information is required by ANSI Z21.10.3

FOR YOUR SAFETY READ BEFORE OPERATING



WARNING

If you do not follow these instructions exactly, a fire or explosion may result causing property damage, personal injury or loss of life.

- A. This appliance does not have a pilot. It is equipped with an ignition device which automatically lights the burner. Do not try to light the burner by hand.
- B. BEFORE OPERATING, smell all around the appliance area for gas. Be sure to smell next to the floor because some gas is heavier than air and will settle on the floor.
WHAT TO DO IF YOU SMELL GAS
 - Do not try to light any appliance.
 - Do not touch any electric switch; do not use any phone in your building.
 - Immediately call your gas supplier from a neighbor's phone. Follow the gas supplier's instructions.
- C. If you cannot reach your gas supplier, call the fire department.
- D. Use only your hand to push in or turn the gas control valve. Never use tools. If the gas control valve will not turn by hand, do not try to repair it, call a qualified service technician. Force or attempted repair may result in a fire or explosion.
- E. Do not use this appliance if any part has been under water. Immediately call a qualified service technician to inspect the appliance and to replace any part of the control system and any gas control which has been under water.

OPERATING INSTRUCTIONS

1. **STOP!** Read the safety information above.
2. Set the temperature controller to lowest setting.
3. Turn off all electric power to the appliance.
4. This appliance does not have a pilot. It is equipped with an ignition device which automatically lights the burner. Do not try to light the burner by hand.
5. Turn the manual gas control valve located at gas inlet of appliance clockwise ↻ to the OFF position.
6. Wait five (5) minutes to clear out any gas. Then smell for gas, including near the floor. If you smell gas, STOP! Follow "B" in the safety information above. If you don't smell gas, go to the next step.
7. Turn the manual gas valve located at gas inlet of appliance counterclockwise ↺ to the full ON position.
8. Turn on all electric power to the appliance.
9. Set the temperature controller to desired setting.
10. If the appliance will not operate, follow the instructions "To Turn Off Gas To Appliance" and call your service technician or gas supplier.

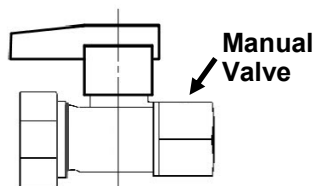

CLOSE

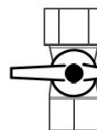

OPEN



TO TURN OFF GAS TO APPLIANCE

1. Set the temperature controller to lowest setting.
2. Turn off all electric power to the appliance if service is to be performed.
3. Turn the manual gas control valve located at gas inlet of appliance clockwise ↻ to the OFF position.

5. Notes

Rinnai America Corporation

103 International Drive
Peachtree City, GA 30269
Tel. 1-800-621-9419
Web. rinnai.us
rinnai.ca

100000815
11/2022